

Installation, Operating & Maintenance Manual

(Original Instructions)

WITTIG



**Rotary Vane
Compressor/Vacuum
Pump electric motor
driven packages**

Models

RFL60

RFL80

RFL100

Table of contents

1 Specifications

1.1 Machine data	5
1.2 Dimensions compressor unit RFL 60	7
1.3 Dimensions compressor unit RFL 80 / 100	8
1.4 Dimensions combined compressor / vacuum pump unit RFL 80 / 100	9
1.5 Dimensions vacuum pump RFL80 / 100 fo braking systems	10

2 Safety rules and warnings

2.1 Use	11
2.2 In service monitoring	11
2.3 Hazard symbols and notices	11
2.4 Work Safety	12

3 Transport

3.1 Transport	13
3.2 Storage	13
3.3 Acceptance of delivery	14

4 Components and description of the unit

4.1 General description	15
4.2 Electrical Equipment	15
4.3 Security and Shut off functions	15
4.4 Package components	15
4.4.1 Non return valve	15
4.4.2 Safety valve (optional)	16
4.4.3 Guarding	16
4.4.4 Restraint system for conveyed	16
4.4.5 Vacuum switches for suction (Optional)	16
4.4.6 Oil level monitor (optional)	17
4.4.7 Cell ventilation (optional)	18

5 Installation of packages

5.1 Installation conditions	19
5.2 Compressed air connection	19
5.3 Electrical Connection	20
5.4 Desiccant	20

6 Commissioning and operation

6.1 Review of the facility	21
6.2 Oil level control	21
6.3 Rotation direction	21
6.4 Switching On and Working pressure control	21
6.4.1 Working pressure	22
6.5 Operation	22
6.5.1 Shutdown procedure	22
6.5.2 Monitoring interval during operation	22

7 Maintenance, dismantling, removal, troubleshooting

7.1 Maintenance intervals and maintenance work	23
7.2 Troubleshooting	23
7.3 Dismantling and disposal	23
7.4 Wear and spare parts	23

8 Wiring Schedule	24
-------------------	----

General Instructions

This operation manual for the RFL 60-100 packages complements the existing operating instructions pertaining to the RFL 60-100.

In this operating and instruction manual are only the sections which relate to the extra packaged equipment around the RFL.

The RFL compressor/ vacuum pump specific operating information is already in their respective manuals and is not repeated here. Related documents are :

Operating instructions RFL 60-100 (T-BA-1150)
Spare parts list RFL 60-100 (T-ET-1150)



Note the figure references used are as detailed below :

The Note (7.2 / 3): 2nd Figure in 7th Chapter, position number 3

1 Specifications

1.1 Machine data

1.2 Dimensions compressor unit RFL 60

1.3 Dimensions compressor unit RFL 80 / 100

1.4 Dimensions combined compressor / vacuum pump unit RFL 80 / 100

1.1 Machine data

The RFL machines are air-cooled and lubricated with fresh oil. They are rotary vane compressors, and are available as compressors, vacuum pumps and combined compressor/vacuum pumps.

On the data plate of each machine you find the model number. The data and images correspond to the models produced as of 01.11.2004. They are subject to change.

Data for the RFL series (compressor)

RFL 60/RFL 80/RFL 100

Air volume at free passage $m^3.h^{-1}$	400/570/700
Flow at 2 bar(g) operating pressure $m^3.h^{-1}$	350/480/580
Suction temperature °C	20/20/20
Suction bar(a)	1/1/1
Operating over pressure bar(g)	2.0/2.0/2.0
1) Safety valve setting Bar(g)	2.5/2.5/2.5
Power demand on the shaft at 2 bar(g) operating pressure kW	20.5/28/37
Rated power electric motor kW	30/37/45
Rated speed min^{-1}	1500/1500/1500
Oil $l.h^{-1}$	0.06/0.075/0.085
Capacity of the oil tank l	5/5/5
Inertia kgm^2	0,187 0,241 0,295
Sound pressure level in 7m At 2 bar(g) operating pressure dB(A)	78/80/82
Weight with electric motor kg	375/560/590



Check the safety valve!

Data for RFL series - combined compressor vacuum pump packages

RFL 80 VR and RFL 100 VR

Air volume at free flow $m^3.h^{-1}$	570/700
Air quantity of residual pressure 400 mbar/60% vacuum $m^3.h^{-1}$	525/640
Operating pressure bar (g)	0.5/0.5
Max excess pressure in compressor use 1) bar(g)	2.0 2.0
Nominal operating vacuum (abs.) 2) mbar /%	200/80 200/80
Maximum vacuum (up to 3 minutes per hour) mbar	200/200
Power demand in the shaft at 0.5 bar pressure kW	17/22
Power demand in the shaft at 2.0 bar pressure kW	28/37
Rated power electric motor kW	30/30
Rated speed $.min^{-1}$	1500/1500
Oil $l.h^{-1}$	0,075/0,085
Contents of oil tank litres	5/5
Inertia kgm^2	0,241/0,241
Sound pressure level in 7m distance at 400 mbar 0.5 bar pressure dB (A)	78/80 80/82
Weight with electric motor kg	365/365



- 1) Secure the relief valve!
- 2) Secure the ventilation valve!

1.2 Dimensions for the compressor package RFL 60

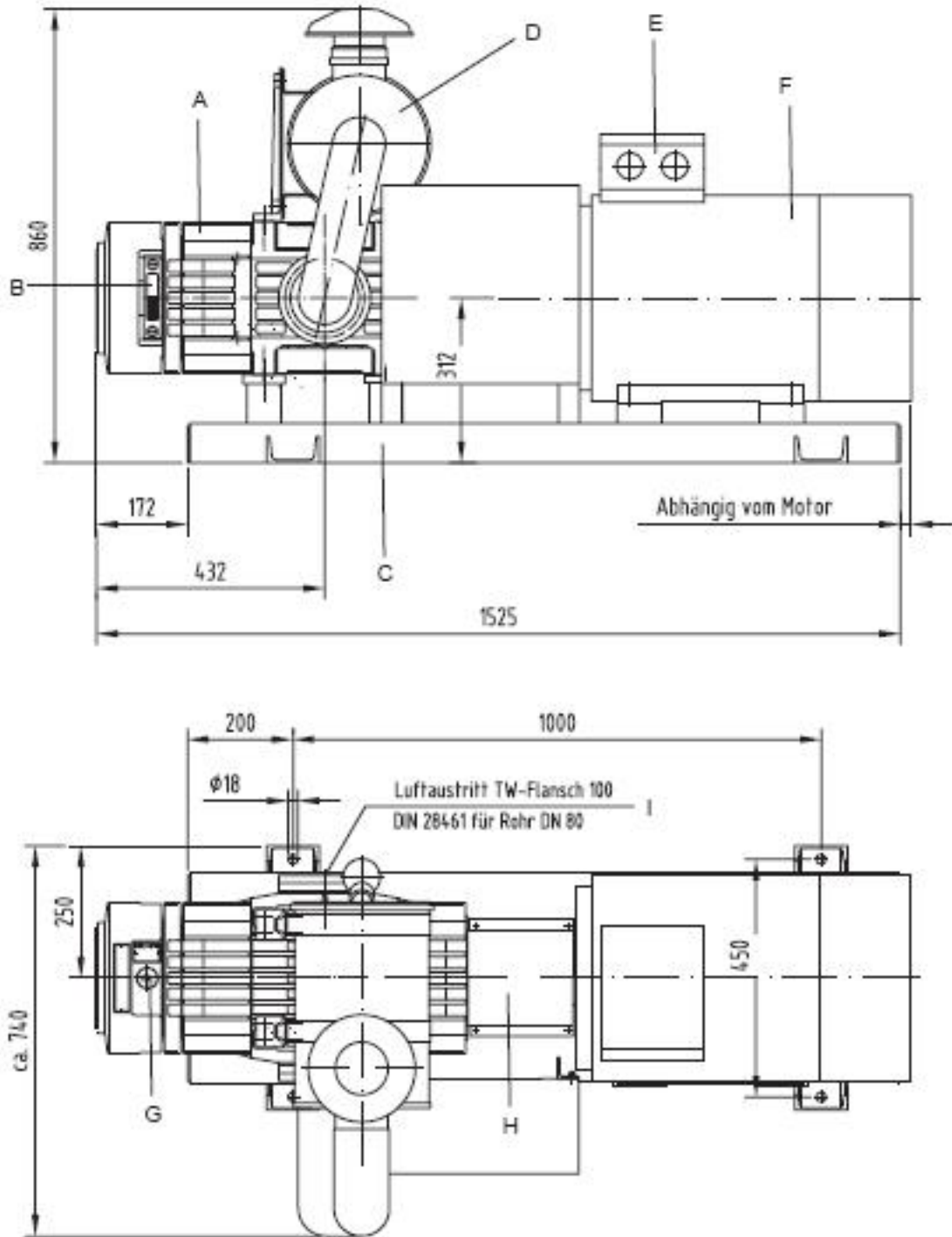

A	Compressor	F	Electric Motor
B	Oil level glass	G	Oil fill point
C	Skid pan base	H	Coupling
D	Air Inlet filter	I	Discharge port
E	Connection box		

Figure 1.1 – dimensions of the RFL 60 compressor package

1.3 Dimensions for the RFL 80 / 100 package

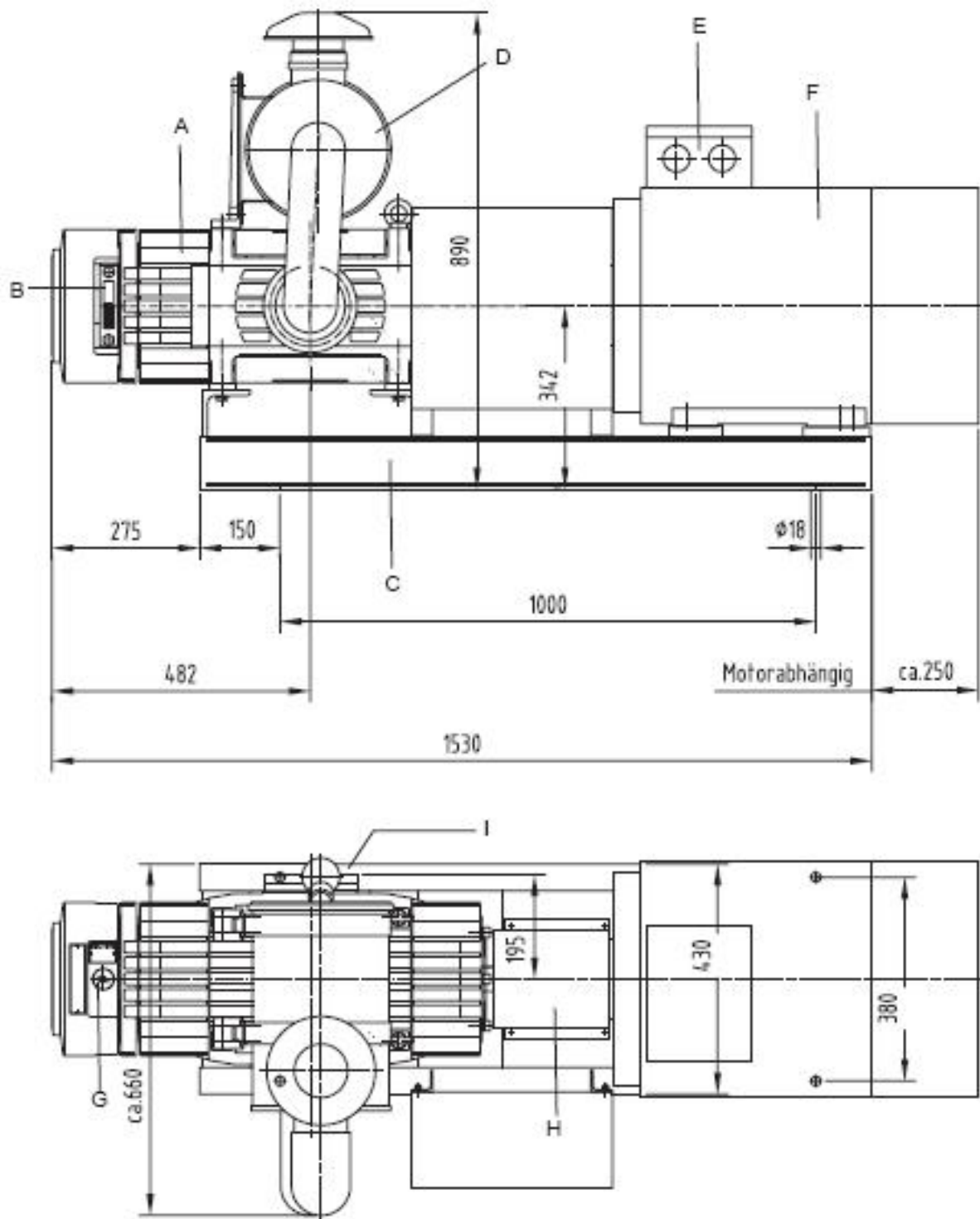

- | | | | |
|---|------------------|---|----------------|
| A | Compressor | F | Electric Motor |
| B | Oil level glass | G | Oil fill point |
| C | Skid pan base | H | Coupling |
| D | Air Inlet filter | I | Discharge port |
| E | Connection box | | |

Figure 1.2 – dimensions of the RFL 80/100 compressor package

1.4 Dimensions for the combined compressor/vacuum pump RFL 80 / 100 package

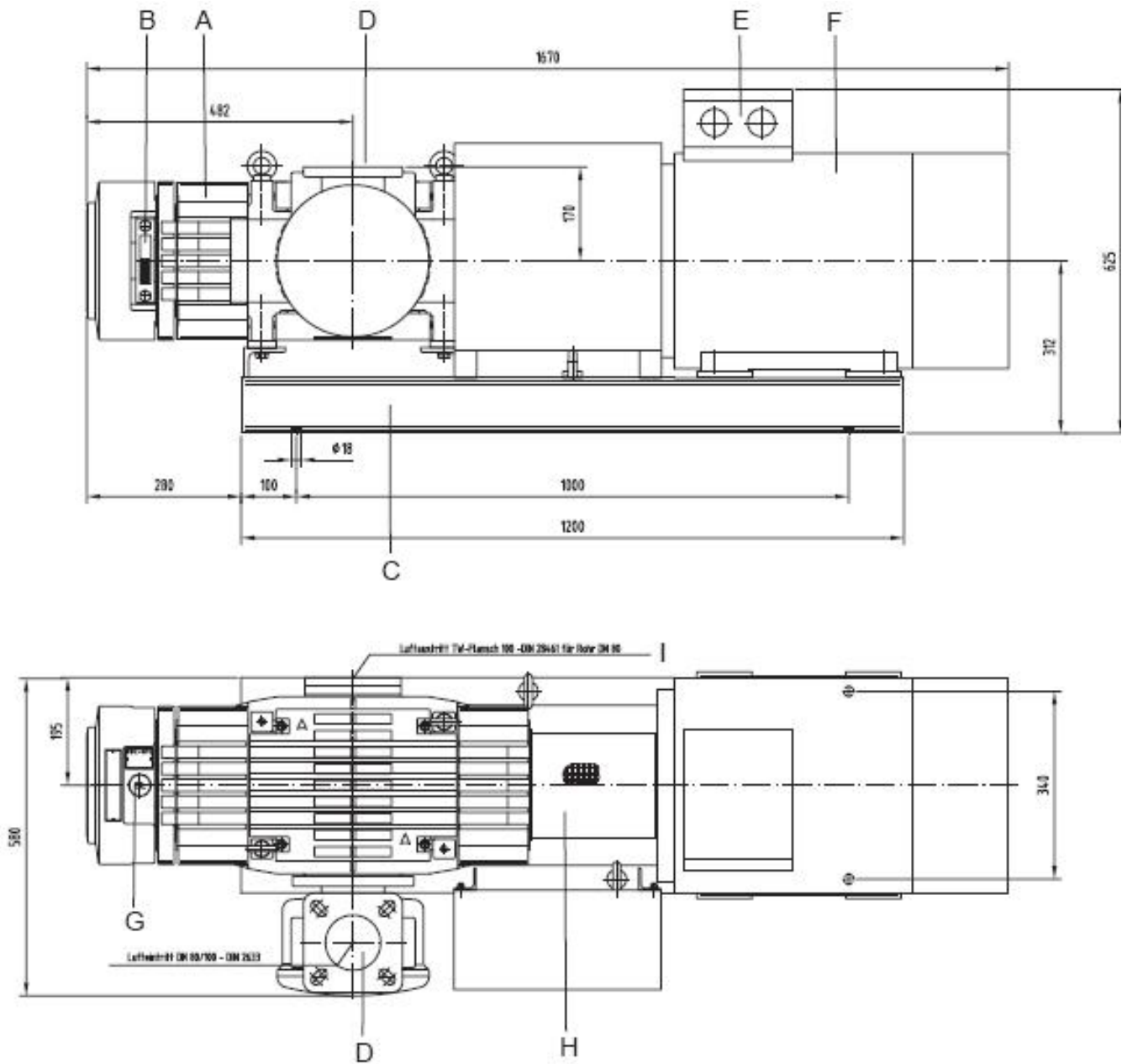

Figure 1.3 – dimensions of the RFL 80/100 combined compressor/vacuum pump package

1.5 Dimensions for the Vacuum pump package RFL 80 / 100 for braking systems

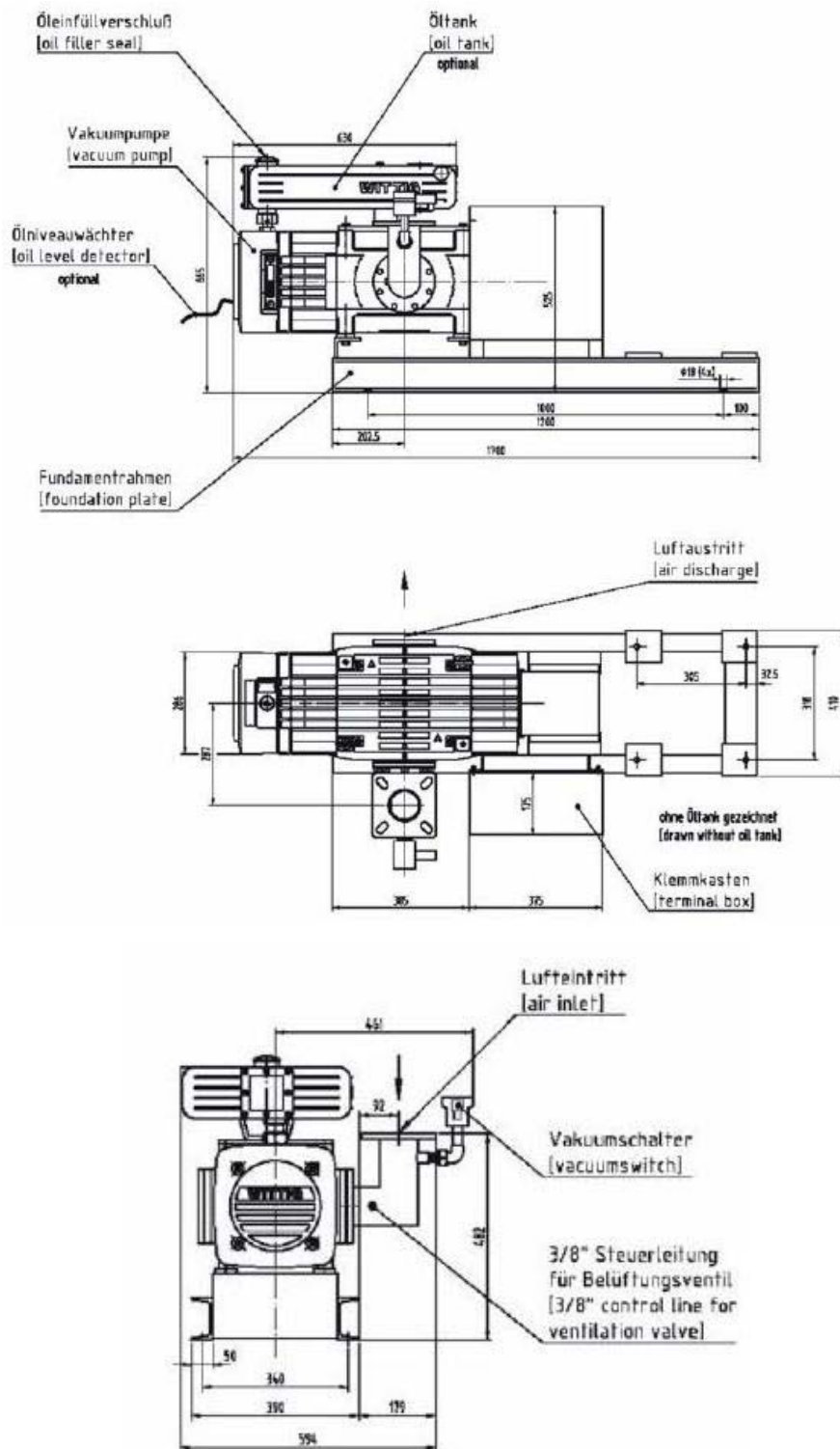

Figure 1.4 Details of the vacuum pump package for braking systems RFL80

2 Safety rules and warnings

2.1 Use

2.2 In service monitoring

2.3 Hazard symbols and notices

2.4 Work Safety

The compressor/vacuum pump unit is a RFL. It is manufactured in accordance with latest developments in technology and recognises all applicable safety rules. Nevertheless, there are risks during operation. To reduce the risk to the body, third party injury or even the risk of death, read the instructions thoroughly. If any aspect is unclear, contact the manufacturer for clarification. Ensure all safety instructions are to be observed.

Using the package outside the specified operational parameters, means the manufacturer cannot accept any liability and may invalidate any warranty.

2.1 Use

The purpose of the unit is to convey product by compacting / sucking filtered air. Use above and beyond this is outside its intended use. The package should not be used in a potentially explosive environment. Use within the guidelines of the manufacturer's instruction, operating data and the listed maintenance schedules.

2.2 In service monitoring

The package itself is not subject to any general inspection and monitoring requirements. In any case, you should follow the safety and accident prevention regulations set out by your governing bodies applicable to the country final usage.

2.3 Hazard symbols and notices



WARNING points to possible dangers to humans. Pay particular attention to the safety demands detailed in the instructions. All users must be aware of any safety precautions.



ATTENTION describes any directives to be followed to avoid damage to the machine.



This symbol indicates information that is important for both operators and the machine itself.



This symbol indicates that environmental protection rules to take note of.



This symbol indicates that a hot surface exists. Combustion danger!



Operating instructions read!



Ear protection!

2.4 Work Safety



Use of this package must be by responsible staff. Prior to working with the package, they must read the operating instructions, particularly this chapter (2) and fully understood it.

- The unit should not be used in a potentially explosive environment.
- Work on electrical equipment must be done by an electrician in accordance with the local electrical power rules.
- Works, maintenance and repairs may only be carried out when the machine is switched off.

Before starting work, check there is no supply to the package. The electrical supply must be totally broken (e.g. fuses removed).

- For maintenance work, do not climb or stand on the package.
- For maintenance work, ensure there is plenty of room around the package to provide a safe working environment.
- When working on the unit, ensure the discharge line is not pressurised. Open any slide valves to ensure the discharge lines depressurise and are as atmospheric air pressure. If necessary, remove the relief valve to ventilate the discharge line.

Check the pressure on the pressure gauge!

- When removing any guarding, ensure that the unit is isolated and locked in the off position.
- Do not maintain the machine until it has fully cooled down. This includes the discharge line.
- Before operation of the machine, ensure the pressure and discharge lines are installed.
- Prior to a re-commissioning the unit following maintenance, ensure that all safety devices are correctly fitted and enabled.
- Any changes to the delivered package which could affect the safety of the unit are inadmissible. Any such proposed modifications must be done an full agreement and with written approval from the manufacturer.
- All warnings on the unit are to be observed in full and in a clearly readable condition.
- Fire alarm and fire-fighting facilities have to be observed.
- The package must be operated in a technically perfect condition.
- Take care to safeguard the operation of the machine with security in mind. Take steps to reduce the operation of the package by unauthorised personnel. In particular, ensure the operating key is not left in the machine when it is switched off.
- Keep the operating instructions in the vicinity of the package.
- Observe the safety rules for transporting (section 3).
- Observe relevant security functions, section 4.3 (Security and Shut off function.)



Environmental protection requires that all leaking fluids during maintenance work, for example, oil and grease are caught and disposed of in an environmentally sound manner.

3 Transport

3.1 Transport

3.2 Storage

3.3 Acceptance of delivery

Symbols on the packaging:



Keep upright



Fragile



Keep dry

3.1 Transport

During transport, the package can be subject to movement and shock loading. Take care when unloading the package with this in mind. The package may be moved using a forklift truck. (See Figure 3.1).

Make sure that the components and parts of the package are not damaged!

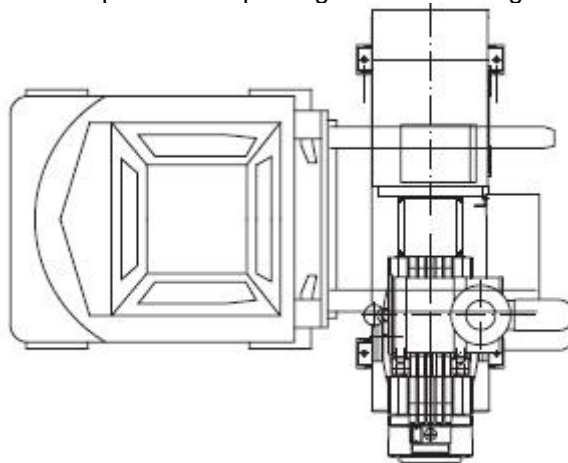

Figure 3.1 Transport of the package by forklift or pallet truck.

Check the package for damage during transport.

Please note that for transportation purposes, the designed weight of the unit is detailed in the Technical Specifications (Chapter 1).

3.2 Storage



Prior to delivery to the point of usage, the package must be kept in a dry, frost-free storage space. Protect the inlet and discharge ports by covering them.

Storage or prolonged periods of inoperation require protection from corrosion. Please contact the manufacturer for details of suitable preservative agents and other measures to prevent corrosion.

3.3 Acceptance of delivery

The contents of the shipment will be detailed on the delivery note. Please check the contents against the delivery note and check for discrepancies or damage. Transport damage and shipment error can only be rectified if the manufacturer is instantly notified in writing.

Figure 3.1 Transportation of the unit with a fork-lift or pallet truck.

3.4 Transportation of vacuum pump for braking system

The attached suction side interface unit (including vacuum switch) is preassembled.



Figure 3.2 Without connecting adapters and vacuum switches



Figure 3.3 With connecting adapters and vacuum switches

4 Components and description of the unit

4.1 General description

4.1.1 Function

4.2 Electrical equipment

4.3 Security and Shut off functions

4.4 Package components

4.4.1 Non return valve

4.4.2 Safety valve (optional)

4.4.3 Guarding

4.4.4 Restraint system for conveyed

4.4.5 Vacuum switches for suction (optional)

4.4.6 Oil level monitor (optional)

4.4.7 Cell ventilation (optional)

4.1 General description

The RFL is an air cooled rotary compressor with oil lubrication. It's function is the compression and suction of filtered air. This package is supplied assembled to the frame. The drive systems is a three-phase motor and if requested, comes with a star-delta-starter / control cabinet (optional).

The unit consists of the components listed in section 1.2 through to section 1.5.

Function : Atmospheric air compressor is drawn into the air filter and then into the rotary compressor. Compressed air is then discharged. When used as a vacuum pump, the suction side of the compressor is connected to the process.

Driving a rotary compressor causes vibration. To compensate for this vibration, the three phase motor is connected by a flexible clutch. Vibration damping can be helped by use of rubber feet (Optional) on the base framework .The package is not designed to be fixed to the floor.

4.2 Electrical Equipment

The electrical equipment of the unit consists of:

- Control cabinet with automatic star-delta switch (Optional)
- Control panel includes keys for start/stop (optional) and operating lamps ON / OFF (optional)

4.3 Security and Shut off function

The following safety and shut off functions are integrated in the packages as optional items:

- optional safety valve on the pressure output (to be loosely supplied)

4.4 Package components

4.4.1 Check valve

The check valve prevents the reverse flow of air within the compressor after shutdown and is built into the compressor.

4.4.2 Relief valve (optional)

The relief valve is supplied loose with the order.

Directive UVV VBG16 requires a non-shutoff safety valve downstream of the compressor. The safety valve must be suitable and ensure that the maximum permitted operating pressure of 2.0 bar gauge cannot be exceeded by more than 10%. Please observe all national regulations regarding this subject.

Check whether the safety valve at 2.0 bar gauge opens at max. 2.2 bar pressure.



Adjustment of the safety valve can result in a pressure rise and temperature rise therefore a DANGER OF EXPLOSION!

Check the operation of the relief valve weekly .

4.4.3 Guarding

Rotating parts are covered by a fixed protective guard.

4.4.4 Restraining system for conveyed material

When used with a silo, the piping must be designed so that the pressure line in all operating conditions, the air flow cannot reverse. This can be achieved by installing a second non return valve immediately before the main flow run is reached.

4.4.5 Vacuum switches for suction (Optional)

The vacuum switch protects the machine from too deep vacuum, leading to a thermal overload. Details of the mechanical vacuum switch

Operating setting	200mbar abs
Switch differential	45mbar
Protection	IP54
Connection	G0.5"
Switch voltage	250VAC / 8A

Connection schedule :-
With increasing pressure:
3-1 opens, 3-2 closes
With decreasing pressure
3-2 opens, 3-1 closes

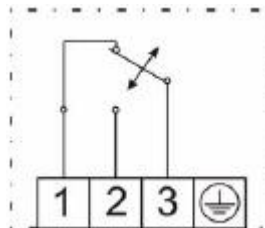

4.4.6 Oil level monitor (optional)

The oil level monitor serves to monitor the oil level in the oil tank.

Figure 4.1 oil tank with oil level monitor.

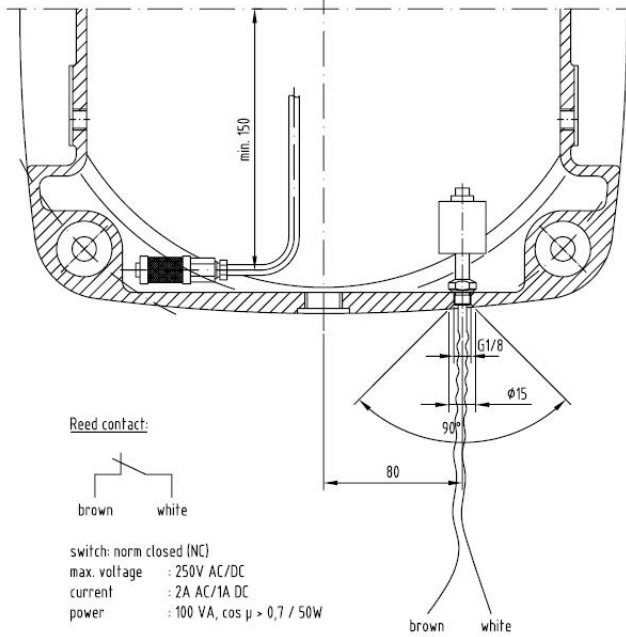
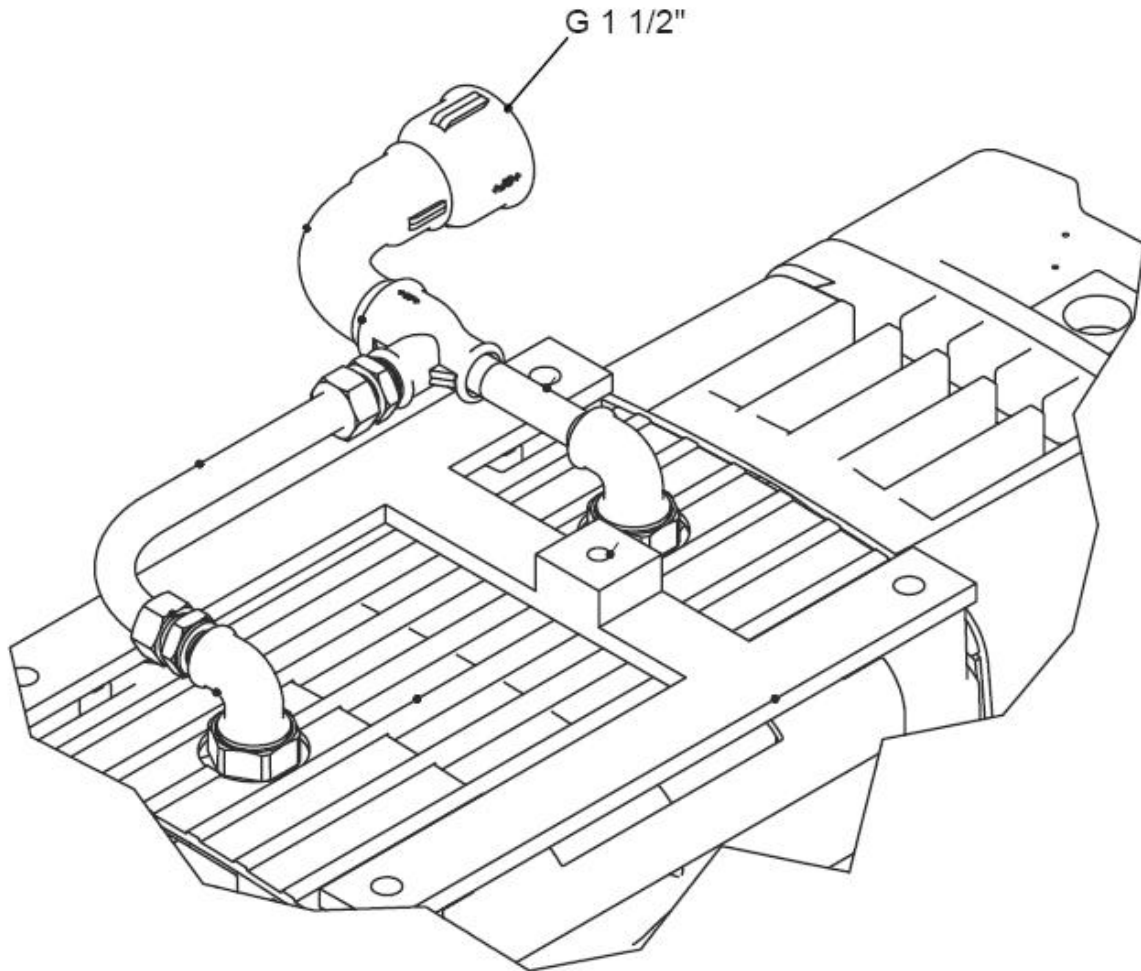

Figure 4.1 oil level tank with oil level monitor

4.4.7 Cell ventilation (optional)

The cell ventilation has a specific function. The design introduces fresh air into the vacuum. The protection against dust at the inlet of the cell ventilation ports is mandatory. The cell ventilation must include at least a 1.5" pipe and must include a ventilation valve and filter (a combined air/oil filter is recommended, see Figure 8.1).

Figure 4.2 connection of the cell ventilation set at 200 mbar. abs



5 Installation of packages

5.1 Installation conditions

5.2 Compressed air connection

5.3 Electrical Connection

5.4 Desiccant

5.1 Installation conditions

The RFL package is fully assembled. (Except when used for braking systems.)

The following conditions must be observed:

- The unit must not be outdoors without appropriate environmental protection.
- Take account so that there is sufficient space for operation and maintenance to be carried out safely.
- The unit can be installed without foundations. However, attention must be paid to the fact that the unit may exert horizontal vibration and the ground works must be able to support the weight (see specifications) of the package and a degree of vibration.
- Good Ventilation in the immediate area of use.
- To protect against excessive dirt within the package, clean air must be sucked in.
- It is the unit intake manifold vacuum switch on +

The suction to assemble (Figure 5.1)



Figure 5.1 Intake manifold and vacuum switches

5.2 Compressed air connection



Attention! Do not start up the unit against a pressurised discharge line.

On preparing discharge pressure pipework, it is imperative to respect and any operating and heat stresses. The pipework must be designed such that the pressure led forces are a dampened by a flexible element.

Connect the pipe flange in accordance with section 1.2-1.4. Any pipe corrosion must be removed by cleaning the pipes internally before installation. This includes any rust, or loose welding spatter.

Following movement of the package from hot to cold areas, condensation may form in the pipe work. Allow this condensation to dry or drain before use.

Note: after the compressor is used, condensation may form and pipework may need to include drainage points.

5.3 Electrical Connection



The installation of electrical connectors, must be done by qualified personnel. During installation ensure there is no mains voltage present!

The control cabinet which will be used to connect the package must incorporate a 3 phase supply. Before connecting the package, check the frequency and amperage required.

The facility within which the package is installed must include the installation of a main isolator switch, which interrupts the power supply to the package.

The electric supply plan for the package must be located in the control panel of the unit which is connected to the package.

5.4 Desiccant



Attention!

If the machine is transported with desiccant bags, ensure that before connecting the machine necessarily all desiccant bags are removed from the compressor / vacuum pump!

6 Commissioning and operation

6.1 Review of the facility

6.2 Oil level control.

6.3 Rotation direction

6.4 Switching On and Working pressure control.

6.4.1 Working pressure

6.5 Operation

6.5.1 Shutdown procedure

6.5.2 Monitoring interval during operation

6.1 Review of the facility

For first time usage and use after a prolonged standstill (more than 4 weeks), this has a major influence on the optimal function of the machine.



Therefore, check commissioning carefully to ensure no steps are overlooked. Damage can result from incorrect commissioning which will invalidate any warranty claims!

Before running the machine for the first time :

- Check the package is correctly connected.
- Check that any additional guarding is in place if required (protection against rotating and hot components).
- Assign operating personnel and leave a copy of these operating instructions in the vicinity of the unit including the operating manual for the RFL and any other relevant documentation and ensure they are thoroughly read.

6.2 Oil level control.

Check the flow of oil in the RFL Compressor/Vacuum Pump according to specific instructions for RFL 60-100.



The oil level must be between the minimum-and-maximum levels of the oil sight glass. Oil levels outside the markings can damage the compressor/vacuum pump.

Caution: Do not overfill!



For disposal of oil, grease, cleaning products or components such as Filter cartridges ensure local environmental protection regulations to be observed.

6.3 Direction of rotation

Quickly turn on the turn off the package to check the direction of rotation. The direction of rotation should be as the directional arrow on the compressor/vacuum pump.

6.4 Switching on and working pressure control.



Turn on the drive with and make sure the vacuum or pressure builds (note the package is not designed to start up against pressure.)

Shut-off the discharge (pressure) slowly to ensure the discharge relief valve opens.

6.4.1 Working pressure

The discharge gauge pressure is 2.0 bar. The maximum gauge pressure is 2.0 bar. Directive UVV VBG16 requires a non-shutoff safety valve downstream the compressor. The safety valve must be suitable and ensure that the maximum permitted operating pressure of 2.0 bar gauge cannot be exceeded by more than 10%. Please observe all national regulations regarding this item.



Check whether the safety valve at 2.0 bar gauge opens at max. 2.2 bar pressure.



Improper installation or arrangement of Compressor and/or tampering with safety valve can lead to pressure and temperature rise of the compressor and thus the risk of failure!

6.5 Operation

After commissioning, simply switch the package on to test its function. No other special commissioning procedures are required.

The unit is suitable for continuous operation.
The unit is either in the ON position or OFF position

6.5.1 Shutdown procedure

With the unit switched on, simply follow by switching it OFF.
(Does not apply vacuum machines for braking).

6.5.2 Monitoring interval during operation

See operating instructions RFL 60-100.

7 Maintenance, dismantling, removal, troubleshooting

7.1 maintenance intervals and maintenance work

7.2 Troubleshooting

7.3 dismantling and disposal

7.4 Wear and spare parts

7.1 maintenance intervals and

Maintenance work

See operating instructions RFL 60-100, document number T-BA-1400

7.2 Troubleshooting

See operating instructions RFL 60-100, document number T-BA-1400.

7.3 Dismantling and disposal



Warning!

The work must be performed by trained personnel.

Disconnect the unit from the electricity supply and the compressor must be depressurised.

For the final dismantling and disposal of the unit ,proceed as follows:

- Disconnect the unit from the supply voltage.
- Disconnect the unit from the compressed air line.
- Allow the oil to settle and dispose of it in an environmentally friendly.
- Remove pipelines and dispose of any oil within them.
- Any metallic parts should be taken to a recycling centre.

7.4 Wear and spare parts

See spare parts list RFL 60-100

See separate spare parts list

8. Wiring

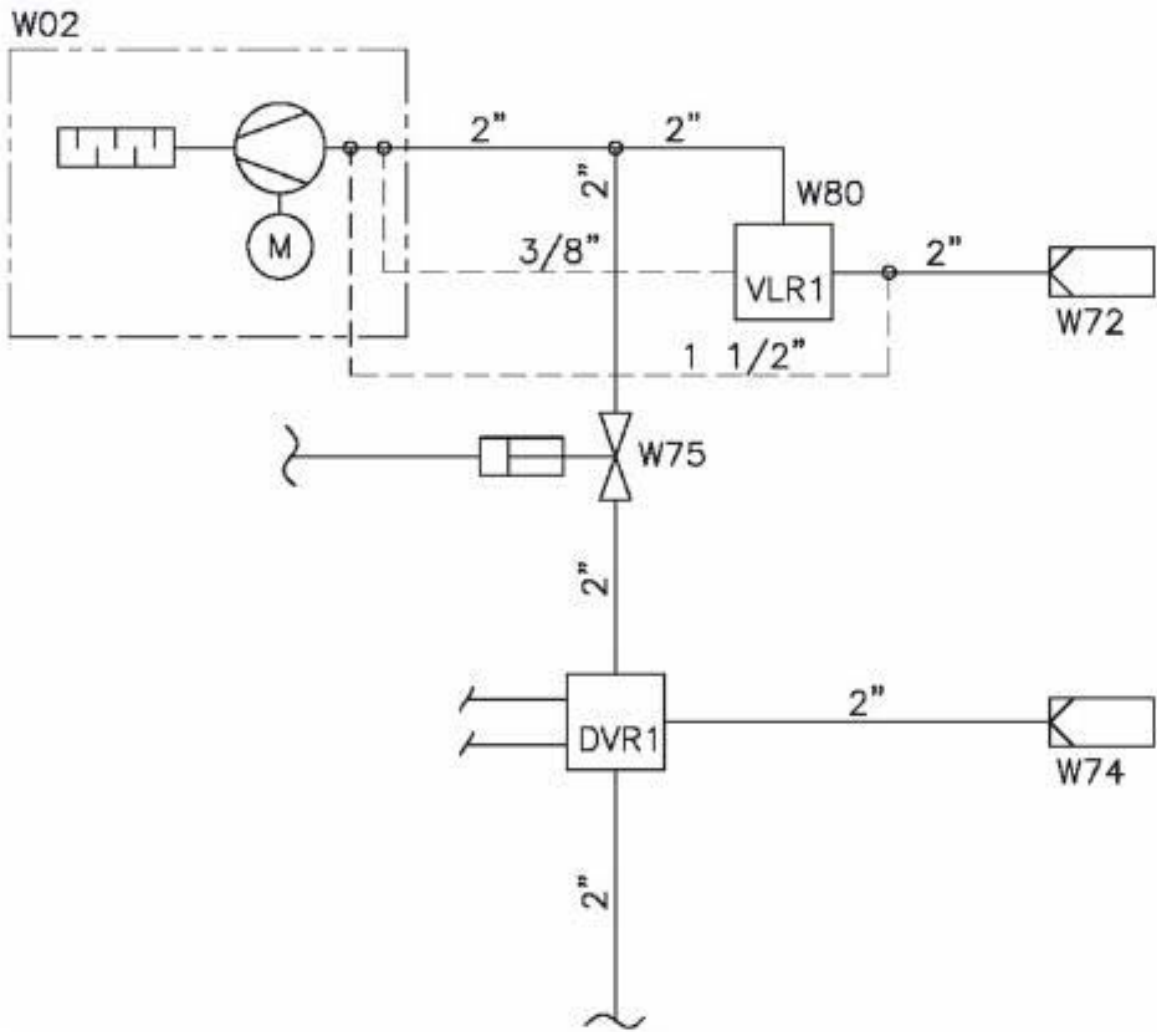

Diagram 8.1 – Wiring scheme

Contact Us

Americas

Gardner Denver, Inc.
Industrial Products Group - Americas
1800 Gardner Expressway
Quincy, IL. 62305
Toll Free: 1-800-682-9868
Phone: 217-222-5400
Fax: 217-221-8780

email: mobilesolutions@gardnerdenver.com

France

Gardner Denver France SA
Division Compresseurs
42, rue du Montmurier, BP 604
38070 Saint-Quentin-Fallavier, France
Phone: +33 (0)474941673
Fax: +33 (0)474941689

email: contact.lyon@gardnerdenver.com

UK Sales & Service

Gardner Denver UK Ltd
PO Box 468
Cross Lane, Tong
Bradford, West Yorkshire
United Kingdom
BD4 0SU
Phone: +44 (0)1274 683131
Fax: +44 (0)1274 651006

email: sales.uk@gardnerdenver.com

Australia

Gardner Denver Ind. Australia Pty Ltd
30 Bearing Road
Seven Hills
New South Wales
2147 Australia
Phone: +61 2 96207000
Fax: +61 2 96207955

email: hermant.malik@gardnerdenver.com

Germany

Gardner Denver Deutschland GmbH
Am Dorn 14
48308 Senden
Germany
Phone: +49 (0)253634840
Fax: +49 (0)25363484010

email: info.de@gardnerdenver.com

Spain

Gardner Denver Iberica S.L.
Calle Primavera, 20
Poligono Industrial Las Monjas
28850 Torrejon de Ardoz
Madrid, Spain
Phone: +34 (0)916560056
Fax: +34 (0)916770496

email: aurelio.fernandez@gardnerdenver.com

Belgium

Gardner Denver Belgium N.V.
Luithagen 7A
Haven 200
B-2030 Antwerpen
Belgium
Phone: +32 (0)3 5415040
Fax: +32 (0)3 5416509

email: info.be@gardnerdenver.com

Netherlands

Gardner Denver Nederland BV
Barwoutswaarder 3B
3449 He Woerden
The Netherlands
Phone: +31 (0)348410150
Fax: +31 (0)348418079

email: sales.nl@gardnerdenver.com

Rest of the World

Gardner Denver Ltd
PO Box 178
Springmill Street
Bradford, West Yorkshire
United Kingdom
BD5 7YH
Phone: +44 (0)1274 718100
Fax: +44 (0)1274 655272

email: gdtransportsales@gardnerdenver.com

For additional information, contact your local representative or

The logo for Gardner Denver, featuring the word "Gardner" in a large, bold, black sans-serif font above the word "Denver" in a similar font. A thick red horizontal line is positioned between the two words, extending from the left edge of "Gardner" to the right edge of "Denver".

Gardner Denver Ltd
PO Box 178,
Springmill Street,
Bradford,
West Yorkshire, UK
BD5 7YH

Tel: +44 (0)1274 718100

Fax: +44 (0)1274 655272

Email: gdtransportsales@gardnerdenver.com

Web: www.gd-transport.com